

# TECHNICAL DATA SHEET

## TORSION SPRING



■ **OPTIONS:**  
- Close turns

### DIMENSIONS

Milimeters	A	B	C <sup>(1)</sup>
Interval min-max	0,4 - 2	50 max	1,5 - 30

(1)  $\varnothing_{\text{mini}} = 3 \times A$

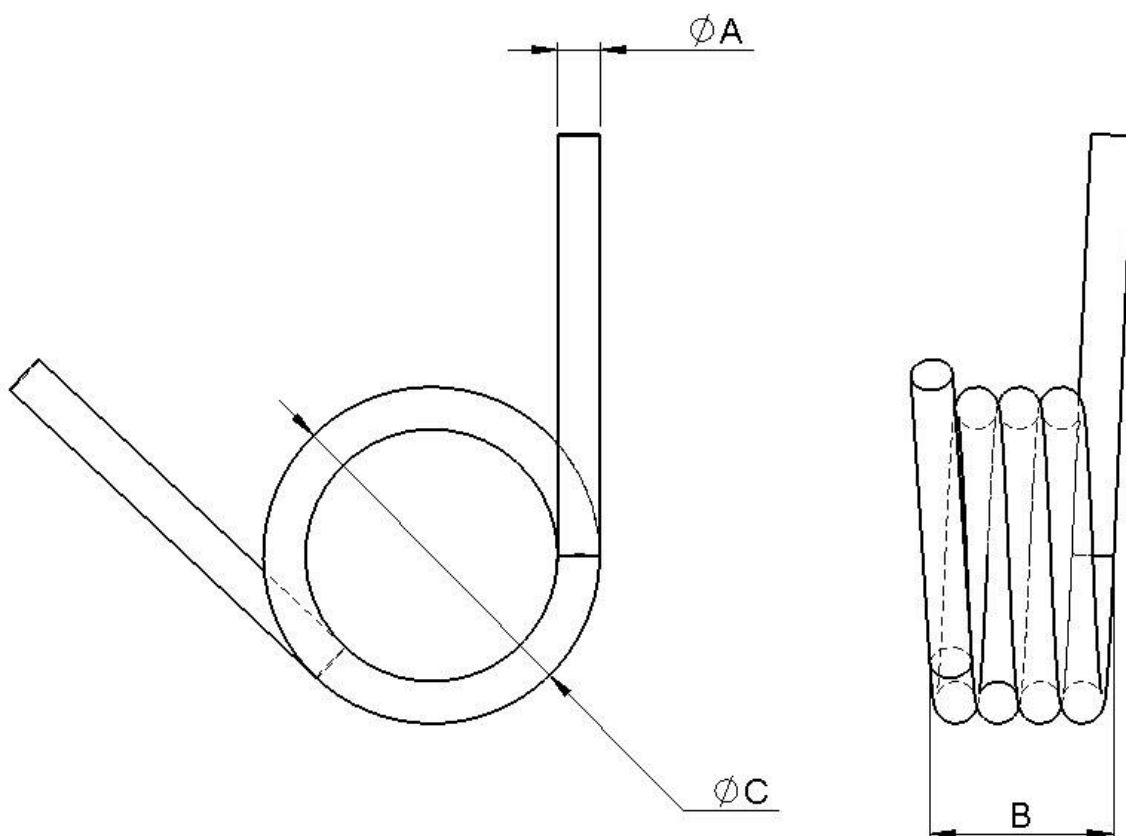

### COMPONENTS

Material		Treatment
Steel	B1 - C1 - D1	Lamellar zinc or zinc nickel
Stainless Steel	302	