

# ATTAX

## TECHNICAL DATA SHEET 505161909

■ FRONT DOUBLE STUD FITTING  
WEIGHT : 160 grs

### FEATURES

#### Characteristics

Fitting class	Quick change
Number of studs	2
Shear plunger	No
F <sub>xz</sub> (for rear) / F <sub>z</sub> (for front)	> 50 KN

#### Aircrafts

AIRBUS				BOEING				OTHERS
A320	A330	A350	A380	B737	B747	B767	B777	(*)
-	-	-	-	●	●	●	-	-

(\*) Indicated for other platforms, contact ATTAX for more information

### COMPONENTS

#### Material

#### Treatment

Body	Stainless steel 17-4 Ph per ASTM A693	Zinc Nickel Type II Grade B per AMS 2417
Plunger	Aluminium 7075-T651	Hard Anodization Type III Class 1 per MIL-A-8625
Lever	Aluminium 7075-T651	Hard Anodization Type III Class 1 per MIL-A-8625

### DIMENSIONS

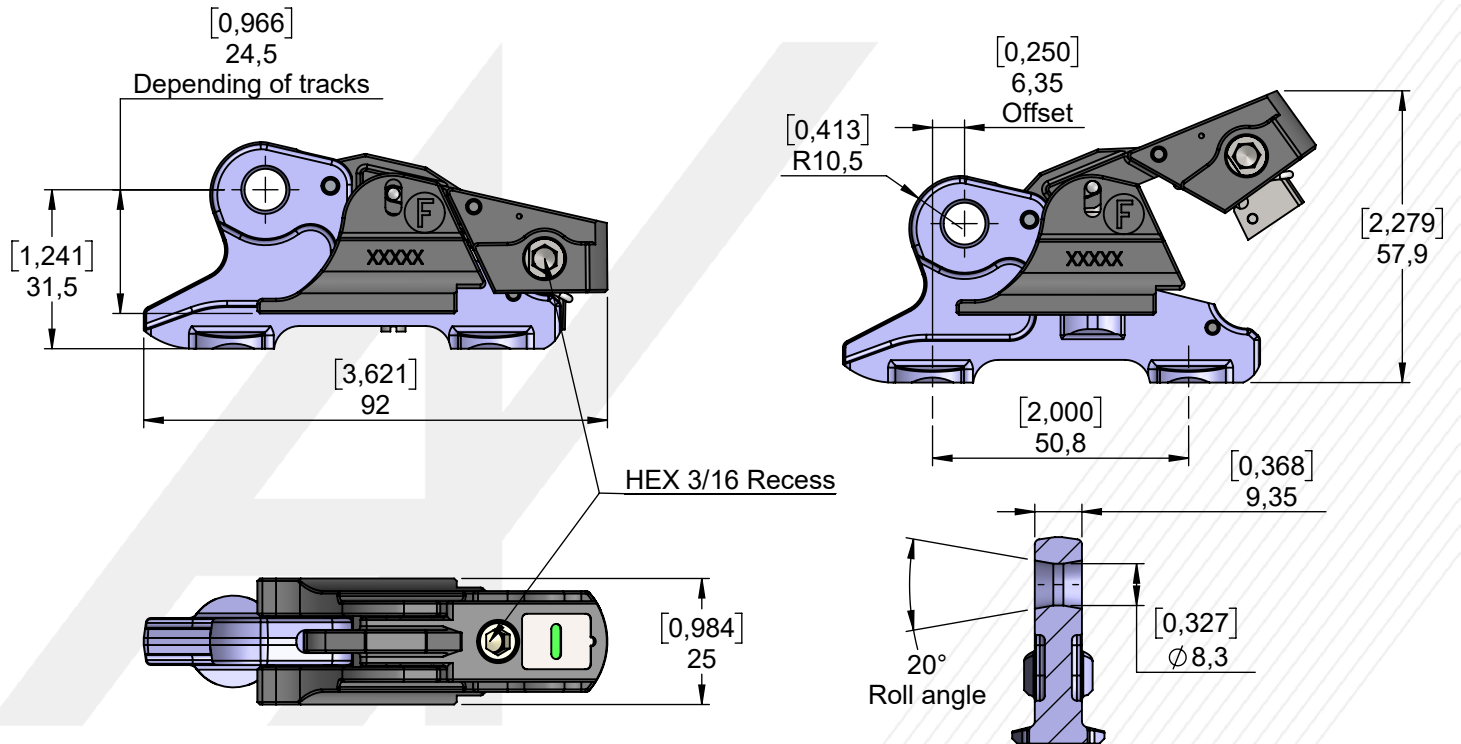

#### Technical data

Safety indicator	Yes	Tool-less	Yes	Secured locking	N/A
Red	Yes	Quick release	Yes	Offset	Yes
Green	Yes	Positive engagement	No	Captive screw	No

This document is the property of ATTAX and shall not be modified or disclosed without prior written authorization. © ATTAX 2019

Revision 17/01/2020

6, rue des Entrepreneurs – ZI les Amandiers  
78420 Carrières-sur-Seine – France  
Phone +33 1 61 045 050 – Fax +33 1 61 040 501  
www.attax.com – info@attax.com

EASA PART 21G  
Approval FR.21G.0295

