



# TECHNICAL DATA SHEET

## 50T4R2001-ZN

■ REAR QUADRUPLE STUD FITTING  
**WEIGHT : 223 grs**

### FEATURES

Characteristics	
Fitting class	Torque
Number of studs	4
Shear plunger	Yes
F <sub>xz</sub> (for rear) / F <sub>z</sub> (for front)	TBD

Aircrafts									
AIRBUS				BOEING				OTHERS	
A320	A330	A350	A380	B737	B747	B767	B777	(*)	
-	-	-	-	-	-	-	-	●	

(\*) Indicated for other platforms, contact ATTAX for more information

### COMPONENTS

Material		Treatment
Body	Stainless steel 17-4 Ph per ASTM A693	Zinc Nickel Type II Grade B per AMS 2417
Plunger	Stainless steel 17-4 Ph per AMS 5355	Zinc Nickel Type II Grade B per AMS 2417
Lever	Aluminium 7075-T651	Hard Anodization Type III Class 1 per MIL-A-8625

### DIMENSIONS

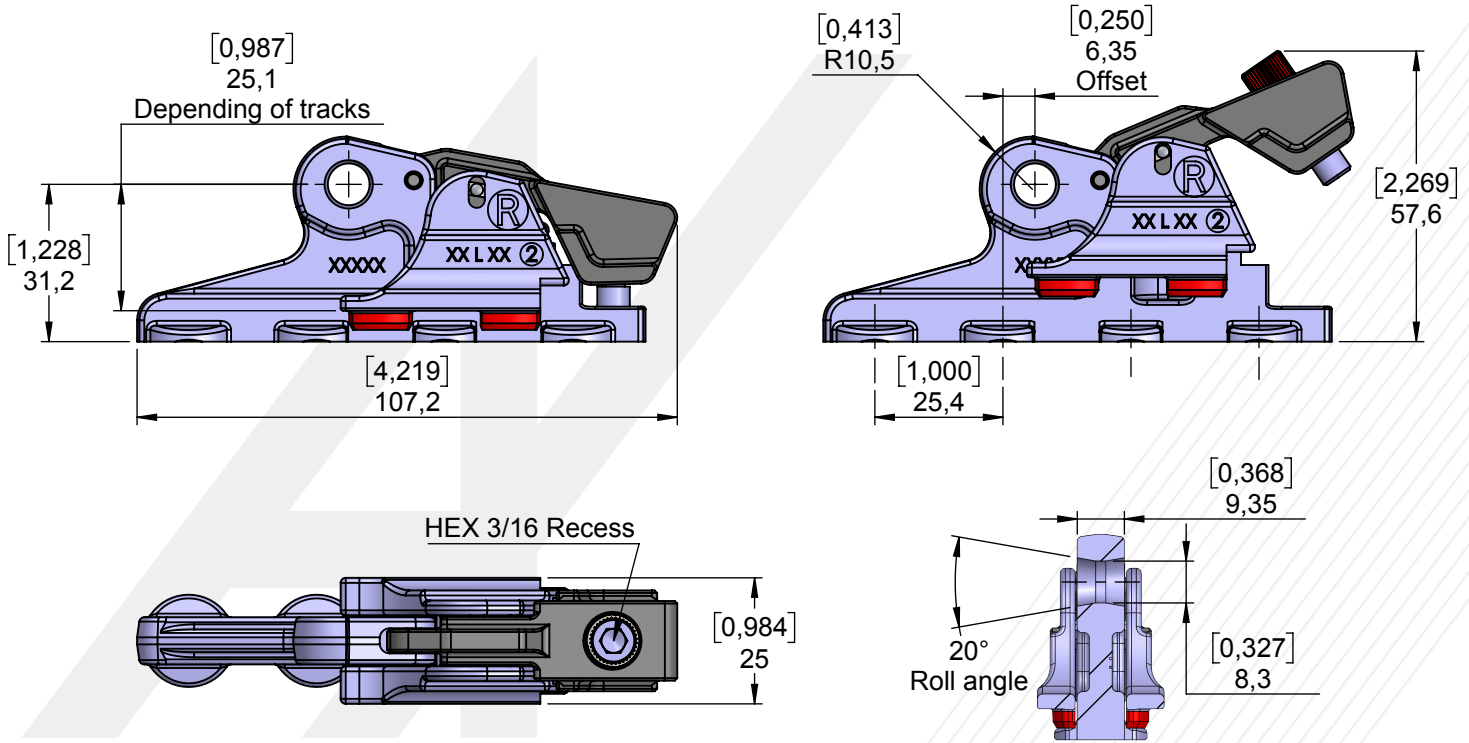

### Technical data

Safety indicator	Yes	Tool-less	No	Secured locking	Yes
Red	Yes	Quick release	No	Offset	Yes
Green	No	Positive engagement	Yes	Captive screw	Yes