

TECHNICAL DATA SHEET

50A3R1001-ZN



■ REAR TRIPLE STUD FITTING
WEIGHT : 210 grs

FEATURES

Characteristics

Fitting class	Quick change
Number of studs	3
Shear plunger	Yes
F _{xz} (for rear) / F _z (for front)	TBD

Aircrafts

AIRBUS				BOEING				OTHERS
A320	A330	A350	A380	B737	B747	B767	B777	(*)
-	-	-	-	-	-	-	-	●

(*) Indicated for other platforms, contact ATTAX for more information

COMPONENTS

Material

Treatment

Body	Steel 4140 per AMS 6349	Zinc Nickel Type II Grade B per AMS 2417
Plunger	Stainless steel 17-4 Ph per AMS 5355	Zinc Nickel Type II Grade B per AMS 2417
Lever	Aluminium 7075-T651	Hard Anodization Type III Class 1 per MIL-A-8625

DIMENSIONS

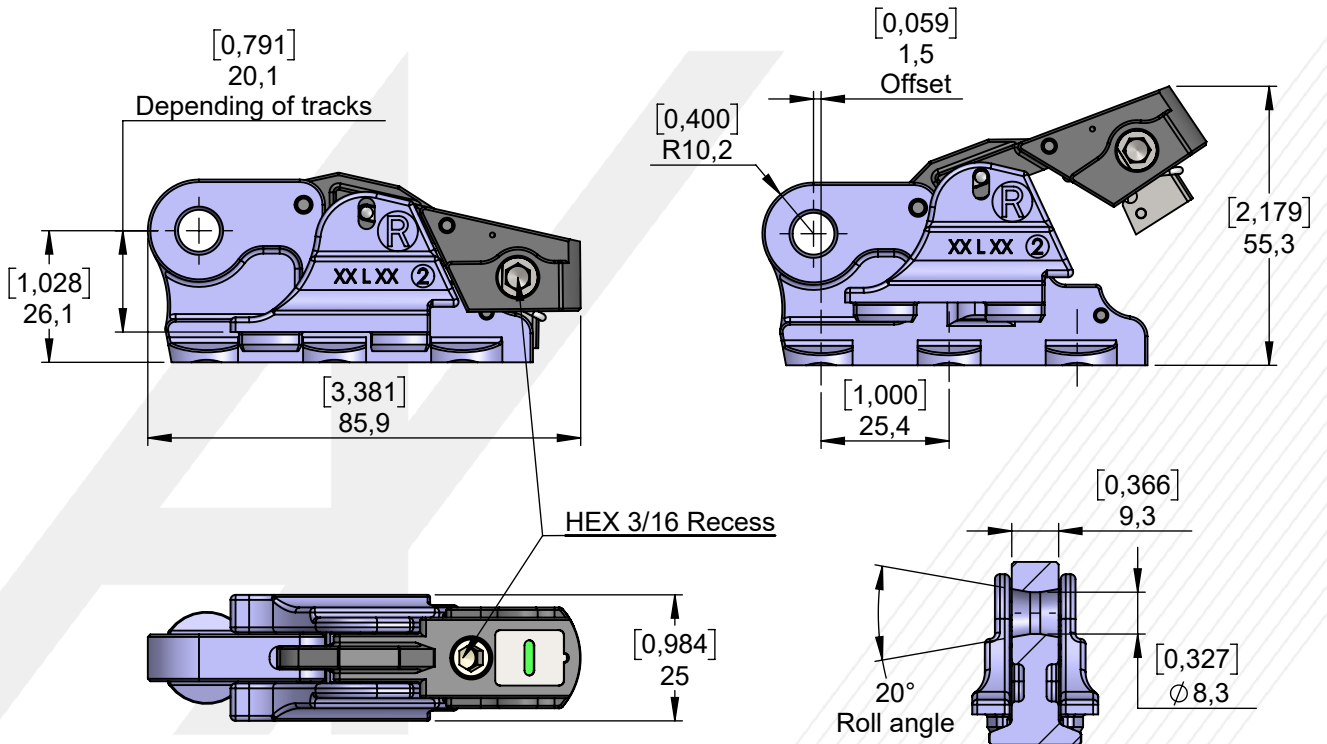

Technical data

Safety indicator	Yes	Tool-less	Yes	Secured locking	Yes
Red	Yes	Quick release	Yes	Offset	Yes
Green	Yes	Positive engagement	Yes	Captive screw	No

This document is the property of ATTAX and shall not be modified or disclosed without prior written authorization. © ATTAX 2019

Revision 28/05/2020

6, rue des Entrepreneurs – ZI les Amandiers
 78420 Carrières-sur-Seine – France
 Phone +33 161 045 050 – Fax +33 161 040 501
 www.attax.com – info@attax.com

EASA PART 21G
 Approval FR.21G.0295

