



TECHNICAL DATA SHEET

50T2F2001-ZN

■ FRONT DOUBLE STUD FITTING
WEIGHT : 188 grs

FEATURES

Characteristics	
Fitting class	Torque
Number of studs	2
Shear plunger	No
F _{xz} (for rear) / F _z (for front)	TBD

Aircrafts									
AIRBUS				BOEING				OTHERS	
A320	A330	A350	A380	B737	B747	B767	B777	(*)	
●	●	-	-	●	●	●	●	-	

(*) Indicated for other platforms, contact ATTAX for more information

COMPONENTS

Material		Treatment
Body	Stainless steel 17-4 Ph per ASTM A693	Zinc Nickel Type II Grade B per AMS 2417
Plunger	Stainless steel 17-4 Ph per AMS 5355	Zinc Nickel Type II Grade B per AMS 2417
Lever	Aluminium 7075-T651	Hard Anodization Type III Class 1 per MIL-A-8625

DIMENSIONS

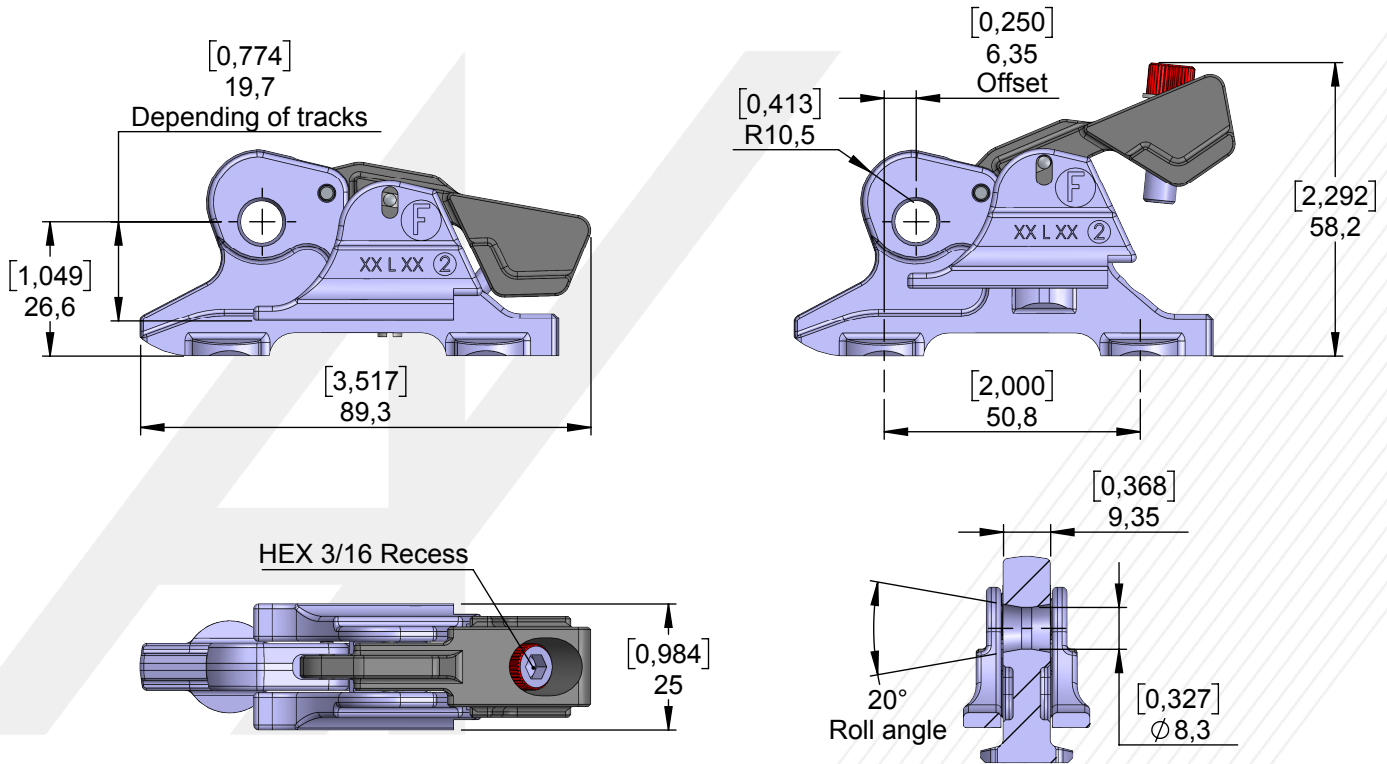

Technical data

Safety indicator	Yes	Tool-less	No	Secured locking	N/A
Red	Yes	Quick release	No	Offset	Yes
Green	No	Positive engagement	No	Captive screw	Yes