

TECHNICAL DATA SHEET

50T3R2001-ZN



■ REAR TRIPLE STUD FITTING
WEIGHT : 209 grs

FEATURES

Characteristics		Aircrafts							
Fitting class	Torque	AIRBUS				BOEING			OTHERS
Number of studs	3	A320	A330	A350	A380	B737	B747	B767	B777 (*)
Shear plunger	Yes	-	-	-	-	-	-	-	●
F _{xz} (for rear) / F _z (for front)	> 70 KN	(*) Indicated for other platforms, contact ATTAX for more information							

COMPONENTS

	Material	Treatment
Body	Stainless steel 17-4 Ph per ASTM A693	Zinc Nickel Type II Grade B per AMS 2417
Plunger	Stainless steel 17-4 Ph per AMS 5355	Zinc Nickel Type II Grade B per AMS 2417
Lever	Aluminium 7075-T651	Hard Anodization Type III Class 1 per MIL-A-8625

DIMENSIONS

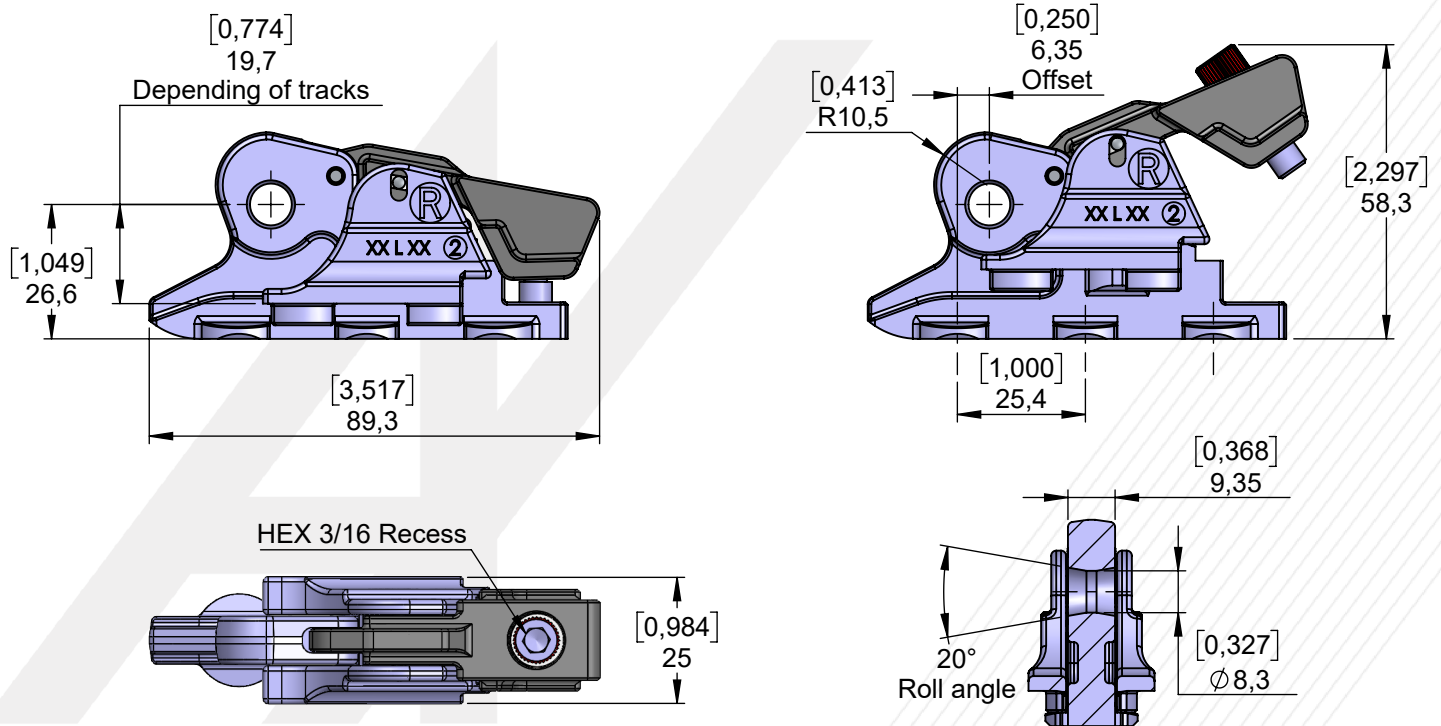

Technical data

Safety indicator	Yes	Tool-less	No	Secured locking	Yes
Red	Yes	Quick release	No	Offset	Yes
Green	No	Positive engagement	Yes	Captive screw	Yes