

## 505045909

■ REAR TRIPLE STUD FITTING  
**Weight : 169 g**



### FEATURES

Characteristics		Aircrafts									
Fitting class	Torque	AIRBUS				BOEING				OTHERS	
Number of studs	3	A320	A330	A350	A380	B737	B747	B767	B777	(*)	
Shear plunger	Yes	●	●	-	-	●	●	●	-	-	
F <sub>xz</sub> (for rear) / F <sub>z</sub> (for front)	> 60 KN	(*) Indicated for other platforms, contact ATTAX for more information									

### COMPONENTS

	Material	Treatment
<b>Body</b>	Steel 4140 per AMS 6349	Zinc Nickel Type II Grade B per AMS 2417
<b>Plunger</b>	Steel 42CrMo4 per EN 10293	Zinc Nickel Type II Grade B per AMS 2417
<b>Lever</b>	--	--

### DIMENSIONS

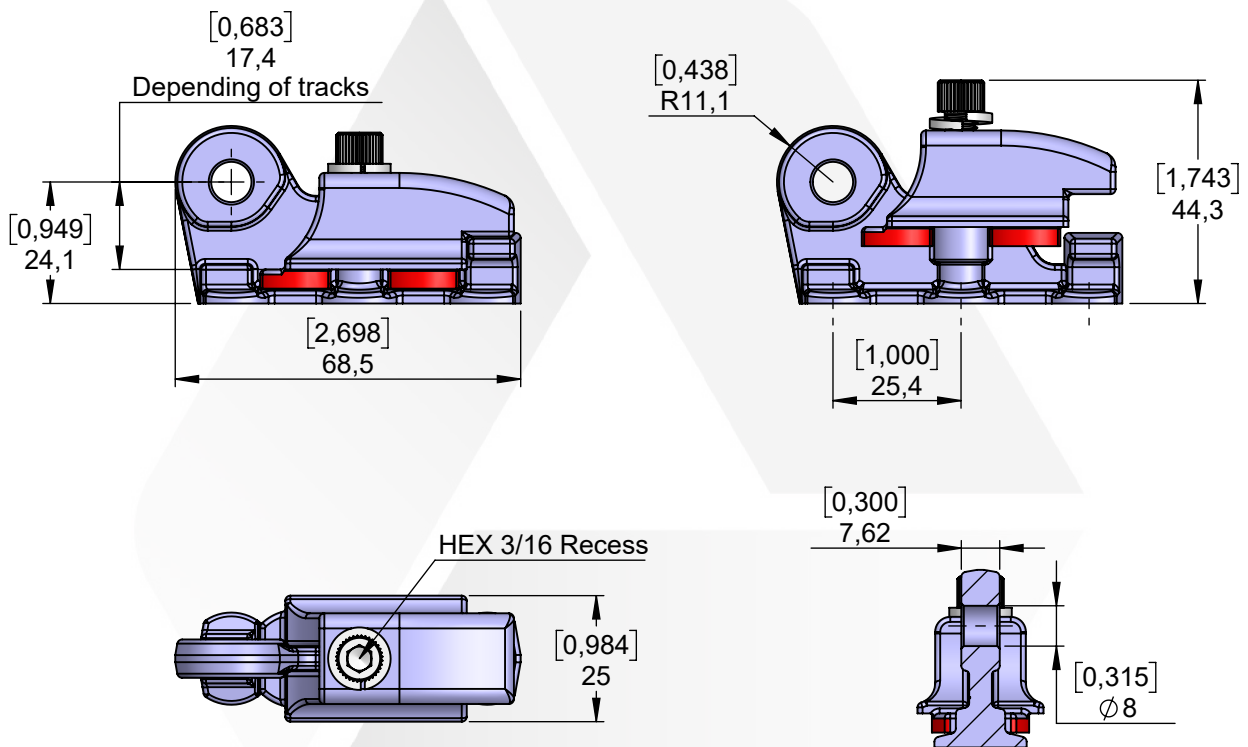

Technical data					
Safety indicator:	Yes	Tool-less	No	Secured locking	No
<b>Red</b>	Yes	Quick release	No	Offset	No
<b>Green</b>	No	Positive engagement	No	Captive screw	No