



## 505143909

FRONT DOUBLE STUD FITTING  
**Weight : 123 g**

### FEATURES

Characteristics	
Fitting class	Torque
Number of studs	2
Shear plunger	No
F <sub>xz</sub> (for rear) / F <sub>z</sub> (for front)	> 50 KN

Aircrafts									
AIRBUS				BOEING				OTHERS	
A320	A330	A350	A380	B737	B747	B767	B777	(*)	
●	●	●	-	-	-	-	-	-	

(\*) Indicated for other platforms, contact ATTAX for more information

### COMPONENTS

	Material	Treatment
Body	Stainless steel 17-4 Ph per ASTM A693	Zinc Nickel Type II Grade B per AMS 2417
Plunger	Aluminium 7075-T651	Hard Anodization Type III Class 1 per MIL-A-8625
Lever	--	--

### DIMENSIONS

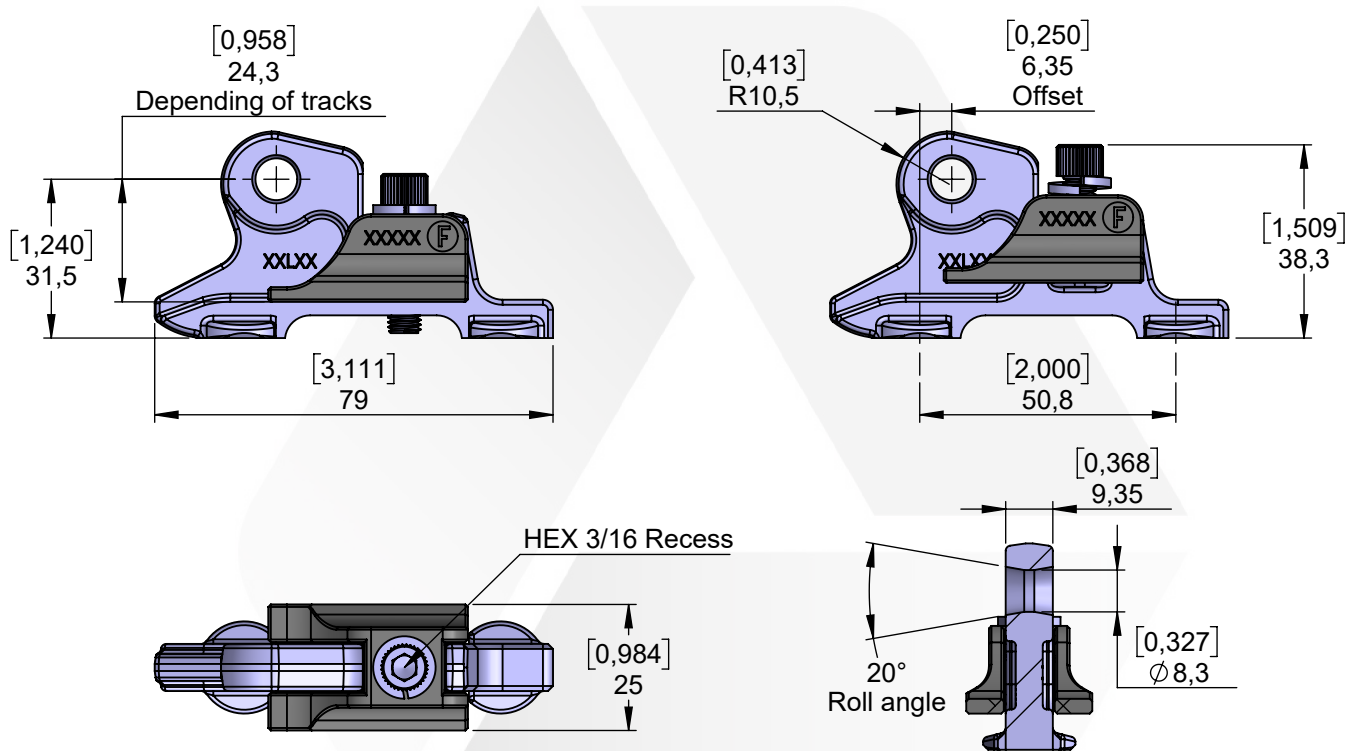

### Technical data

Safety indicator: No	Tool-less	No	Secured locking	N/A
Red No	Quick release	No	Offset	Yes
Green No	Positive engagement	No	Captive screw	Yes