



50T2F1003-ZN

FRONT DOUBLE STUD FITTING
Weight : 200 g

FEATURES

Characteristics	
Fitting class	Torque
Number of studs	2
Shear plunger	No
F _{xz} (for rear) / F _z (for front)	> 50 KN

Aircrafts									
AIRBUS				BOEING				OTHERS	
A320	A330	A350	A380	B737	B747	B767	B777	(*)	
●	●	-	-	●	●	●	●	-	

(*) Indicated for other platforms, contact ATTAX for more information

COMPONENTS

	Material	Treatment
Body	Steel 4140 per AMS 6349	Zinc Nickel Type II Grade B per AMS 2417
Plunger	Steel 42CrMo4 per AMS 6349	Zinc Nickel Type II Grade B per AMS 2417
Lever	Steel 42CrMo4 per AMS 6349	Zinc Nickel Type II Grade B per AMS 2417

DIMENSIONS

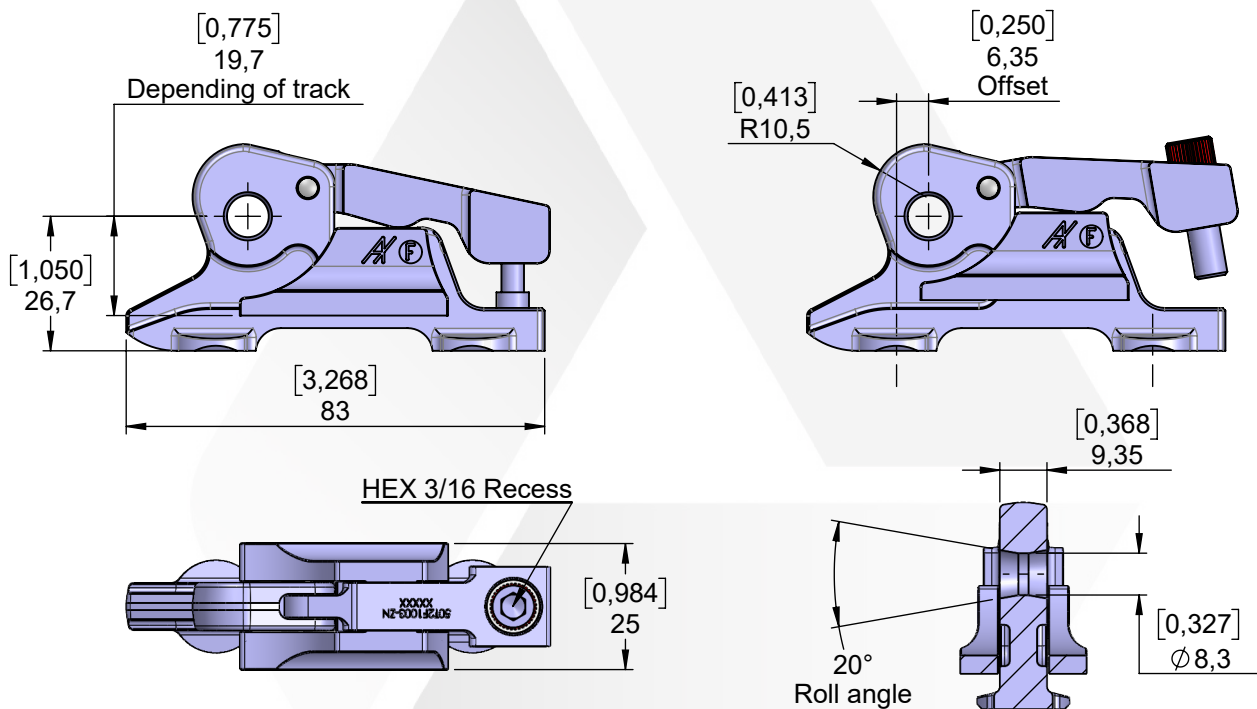

Technical data

Safety indicator: Yes	Tool-less	No	Secured locking	N/A
Red Yes	Quick release	No	Offset	Yes
Green No	Positive engagement	No	Captive screw	Yes