

50T 3R1 001-ZN

■ REAR FITTING TRIPLE STUD
Weight : 137 g



FEATURES

Characteristics	
Fitting class	Torque
Number of studs	3
Shear plunger	Yes
F _{xz} (for rear) / F _z (for front)	> 60 KN

Aircrafts									
AIRBUS				BOEING				OTHERS	
A320	A330	A350	A380	B737	B747	B767	B777	(*)	
●	●	-	-	●	●	●	-	-	

(*) Indicated for other platforms, contact ATTAX for more information

COMPONENTS

	Material	Treatment
Body	Steel 4140 per AMS 6349	Zinc Nickel Type II Grade B per AMS 2417
Plunger	Steel 42CrMo4 per EN 10293	Zinc Nickel Type II Grade B per AMS 2417
Lever	--	--

DIMENSIONS

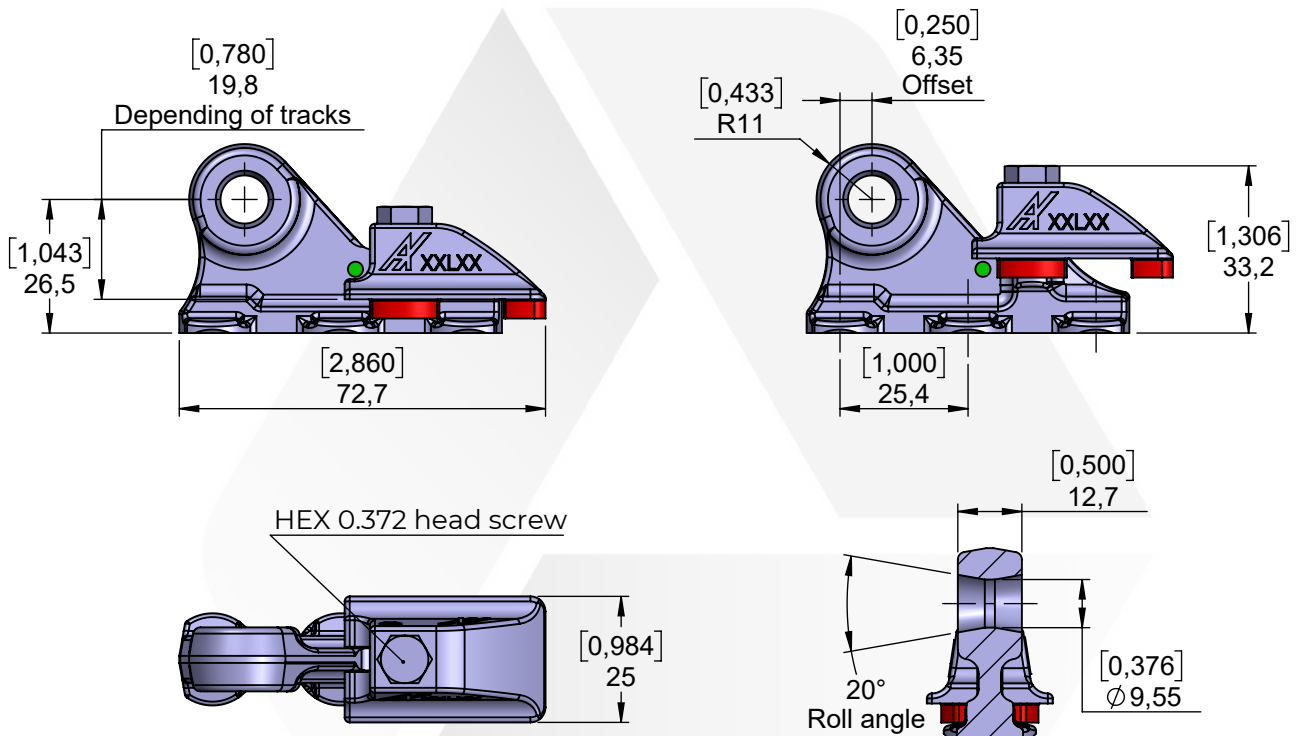

Technical data				
Safety indicator: Yes	Tool-less	No	Secured locking	No
Red Yes	Quick release	No	Offset	Yes
Green Yes	Positive engagement	No	Captive screw	No