

# TECHNICAL DATA SHEET

## 50T3R1002-ZN

■ REAR TRIPLE STUD FITTING  
**Weight : 144 g**



### FEATURES

Characteristics	
Fitting class	Torque
Number of studs	3
Shear plunger	Yes
F <sub>xz</sub> (for rear) / F <sub>z</sub> (for front)	> 60 KN

Aircrafts									
AIRBUS				BOEING				OTHERS	
A320	A330	A350	A380	B737	B747	B767	B777	(*)	
●	●	-	-	●	●	●	-	-	

(\*) Indicated for other platforms, contact ATTAX for more information

### COMPONENTS

	Material	Treatment
<b>Body</b>	Steel 4140 per AMS 6349	Zinc Nickel Type II Grade B per AMS 2417
<b>Plunger</b>	Steel 42CrMo4 per EN 10293	Zinc Nickel Type II Grade B per AMS 2417
<b>Lever</b>	--	--

### DIMENSIONS

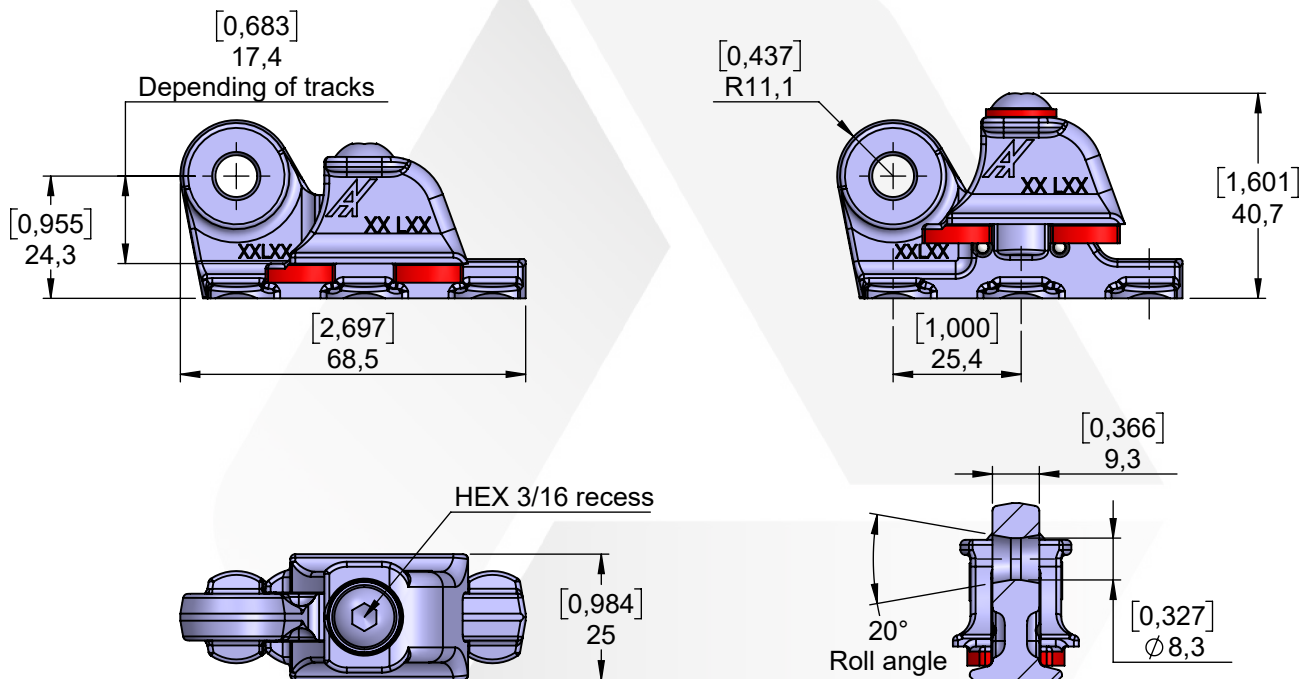

### Technical data

Safety indicator: Yes	Tool-less	No	Secured locking	Yes
Red Yes	Quick release	No	Offset	No
Green No	Positive engagement	Yes	Captive screw	Yes

This document is the property of ATTAX and shall not be modified or disclosed without prior written authorization. © ATTAX 2022

Issue 13/05/2022.