

## 50T3R1004-ZN

■ REAR TRIPLE STUD FITTING  
**Weight : 184 g**



### FEATURES

Characteristics	
Fitting class	Torque
Number of studs	3
Shear plunger	Yes
F <sub>xz</sub> (for rear) / F <sub>z</sub> (for front)	TBD

Aircrafts									
AIRBUS				BOEING				OTHERS	
A320	A330	A350	A380	B737	B747	B767	B777	(*)	
-	-	-	-	-	-	-	-	●	

(\*) Indicated for other platforms, contact ATTAX for more information

### COMPONENTS

	Material	Treatment
Body	Steel 42CrMo4 per EN 10293	Zinc Nickel Type II Grade B per AMS 2417
Plunger	Steel 42CrMo4 per EN 10293	Zinc Nickel Type II Grade B per AMS 2417
Lever	--	--

### DIMENSIONS

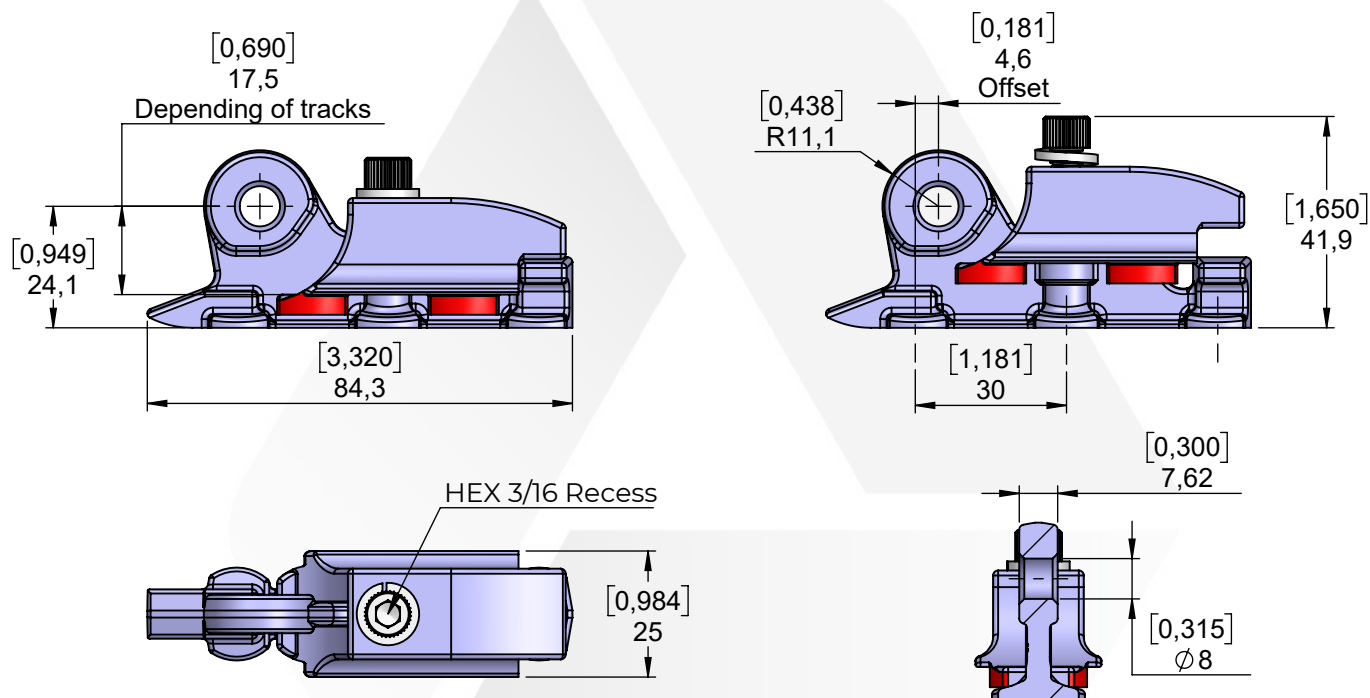

### Technical data

Safety indicator: Yes	Tool-less	No	Secured locking	No
Red Yes	Quick release	No	Offset	Yes
Green No	Positive engagement	No	Captive screw	No