



50T3R1006-ZN

■ REAR TRIPLE STUD FITTING
Weight : 174 g

FEATURES

Characteristics		Aircrafts								
Fitting class	Torque	AIRBUS			BOEING				OTHERS	
Number of studs	4	A320	A330	A350	A380	B737	B747	B767	B777	(*)
Shear plunger	Yes	●	●	●	-	●	●	●	-	-
F _{xz} (for rear) / F _z (for front)	TBD	(*) Indicated for other platforms, contact ATTAX for more information								

COMPONENTS

	Material	Treatment
Body	Stainless steel 17-4 Ph per ASTM A693	Zinc Nickel Type II Grade B per AMS 2417
Plunger	Stainless steel 17-4 Ph per AMS 5355	Zinc Nickel Type II Grade B per AMS 2417
Lever	--	--

DIMENSIONS

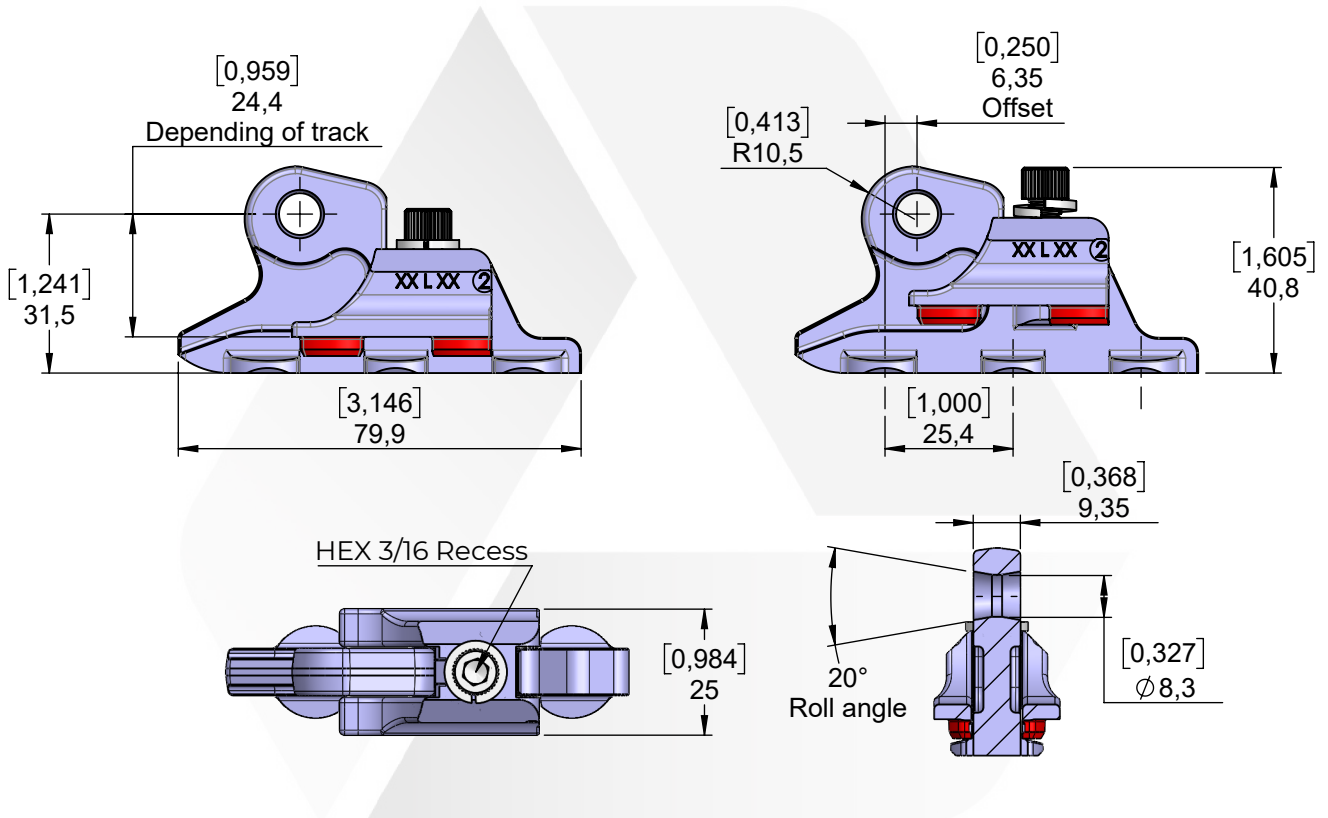

Technical data

Safety indicator: Yes	Tool-less	No	Secured locking	No
Red Yes	Quick release	No	Offset	Yes
Green No	Positive engagement	No	Captive screw	No