

## 50T3R1007-ZN

■ REAR TRIPLE STUD FITTING  
**Weight : 229 g**



### FEATURES

Characteristics	
Fitting class	Torque
Number of studs	3
Shear plunger	Yes
F <sub>xz</sub> (for rear) / F <sub>z</sub> (for front)	> 70 KN

Aircrafts									
AIRBUS				BOEING				OTHERS	
A320	A330	A350	A380	B737	B747	B767	B777	(*)	
-	-	-	●	-	-	-	-	-	

(\*) Indicated for other platforms, contact ATTAX for more information

### COMPONENTS

	Material	Treatment
<b>Body</b>	Steel 42CrMo4 per AMS 6349	Zinc Nickel Type II Grade B per AMS 2417
<b>Plunger</b>	Stainless steel 17-4 Ph per AMS 5355	Zinc Nickel Type II Grade B per AMS 2417
<b>Lever</b>	Aluminium 7075-T651	Hard Anodization Type III Class 1 per MIL-A-8625

### DIMENSIONS

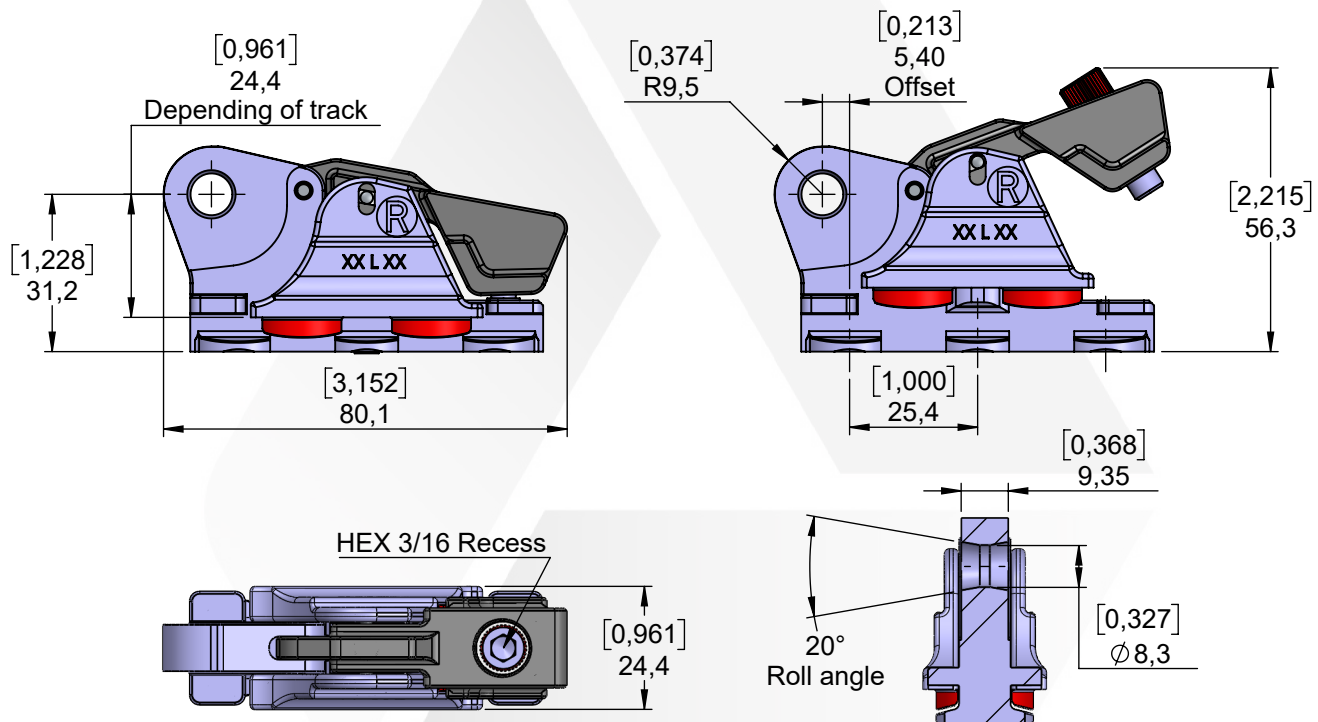

### Technical data

Safety indicator: Yes	Tool-less	No	Secured locking	Yes
Red Yes	Quick release	No	Offset	Yes
Green No	Positive engagement	Yes	Captive screw	Yes