

50T4R2002-ZN

■ REAR QUADRUPLE STUD FITTING

Weight : 191 g



ATTAX

FEATURES

Characteristics

Fitting class	Torque
Number of studs	4
Shear plunger	Yes
F _{xz} (for rear) / F _z (for front)	> 75 KN

Aircrafts

AIRBUS				BOEING				OTHERS
A320	A330	A350	A380	B737	B747	B767	B777	(*)
-	-	-	-	-	-	-	-	●

(*) Indicated for other platforms, contact ATTAX for more information

COMPONENTS

Material Treatment

Body	Stainless steel 17-4 Ph per ASTM A693	Zinc Nickel Type II Grade B per AMS 2417
Plunger	Stainless steel 17-4 Ph per AMS 5355	Zinc Nickel Type II Grade B per AMS 2417
Lever	--	--

DIMENSIONS

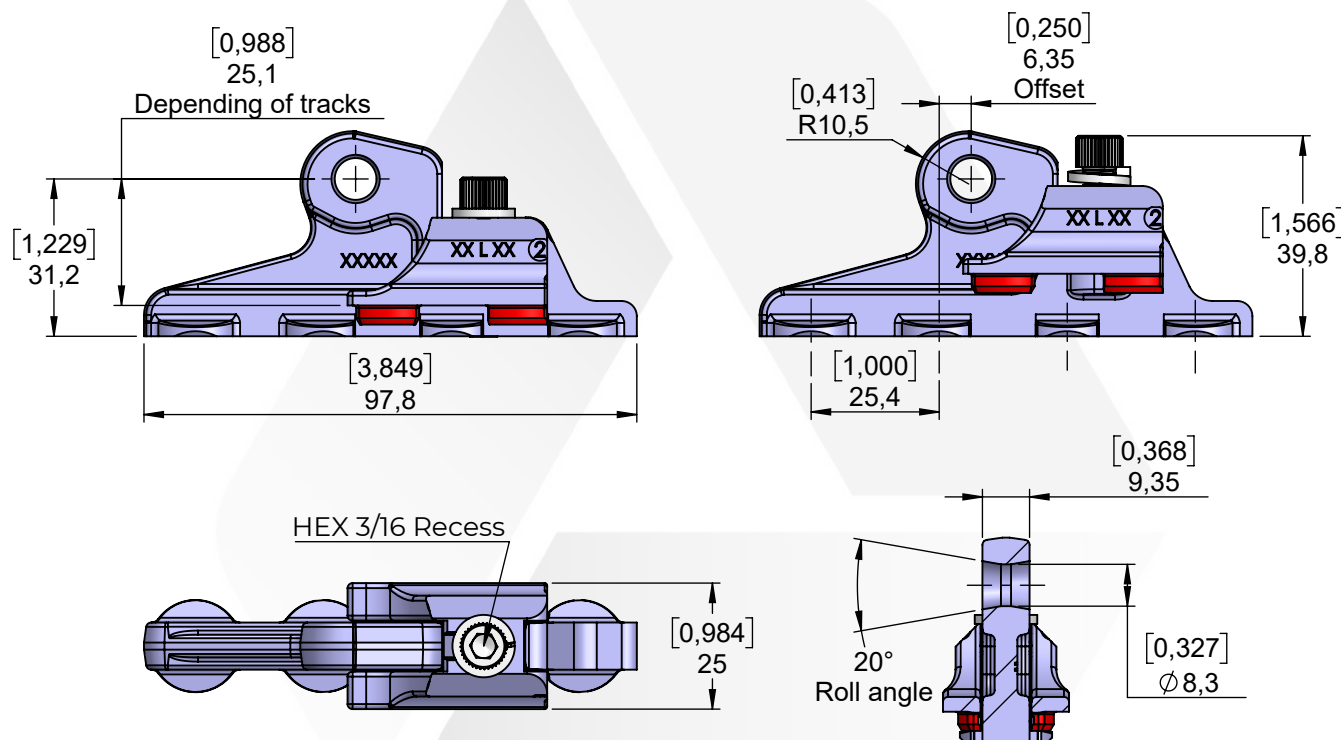

Technical data

Safety indicator: Yes	Tool-less	No	Secured locking	No
Red Yes	Quick release	No	Offset	Yes
Green No	Positive engagement	No	Captive screw	No