

E12282-V4

■ REAR TRIPLE STUD FITTING
Weight : 191 g



FEATURES

Characteristics		Aircrafts								
Fitting class	Single movement	AIRBUS				BOEING				OTHERS
Number of studs	3	A320	A330	A350	A380	B737	B747	B767	B777	(*)
Shear plunger	Yes	●	●	●	●	●	●	●	-	-
F _{xz} (for rear) / F _z (for front)	> 60 KN	(*) Indicated for other platforms, contact ATTAX for more information								

COMPONENTS

	Material	Treatment
Body	Steel 4140 per AMS 6349	Zinc Nickel Type II Grade B per AMS 2417
Plunger	Steel 42CrMo4 per EN 10293	Zinc Nickel Type II Grade B per AMS 2417
Lever	--	--

DIMENSIONS

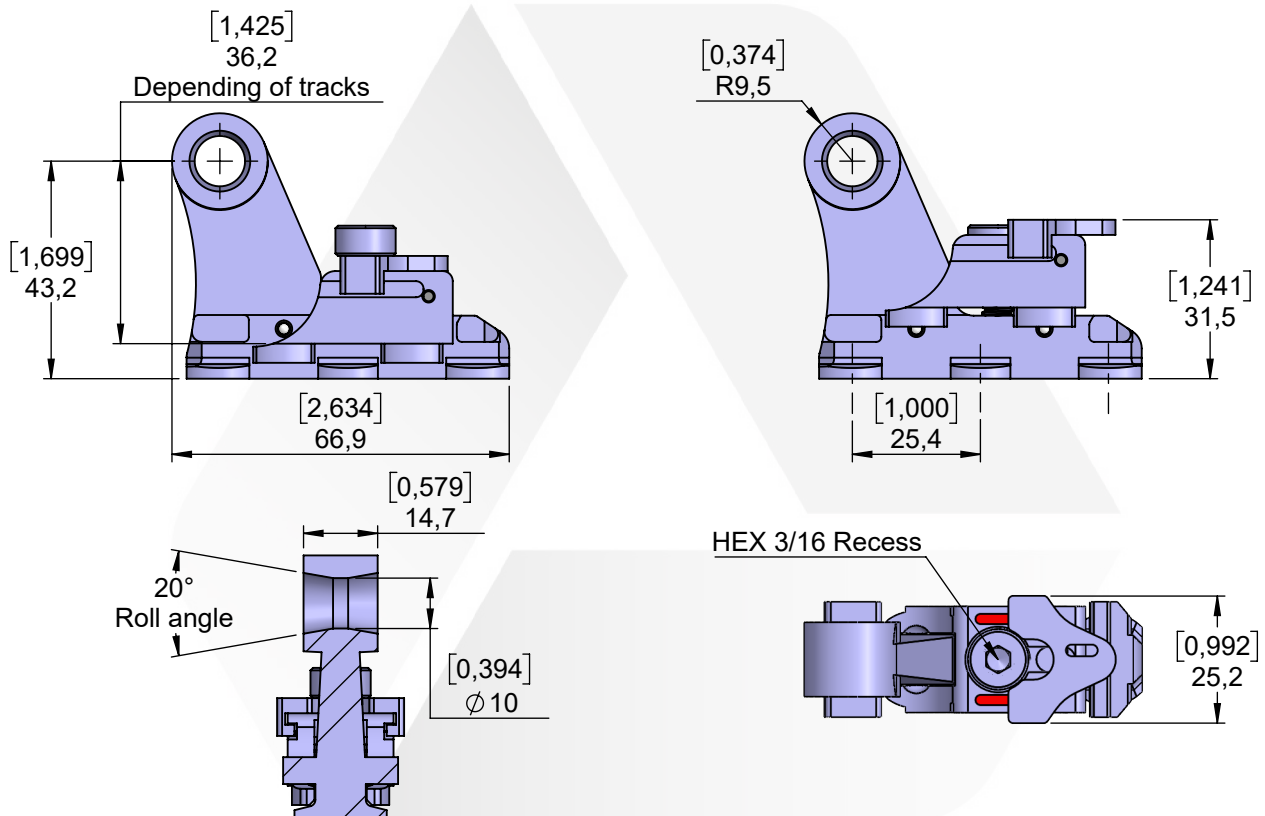

Technical data				
Safety indicator: Yes	Tool-less	No	Secured locking	Yes
Red Yes	Quick release	No	Offset	No
Green No	Positive engagement	Yes	Captive screw	Yes