

E12284-V4

■ REAR QUADRUPLE STUD FITTING
Weight : 223 g



FEATURES

Characteristics	
Fitting class	Single movement
Number of studs	4
Shear plunger	Yes
F _{xz} (for rear) / F _z (for front)	> 60 KN

Aircrafts									
AIRBUS					BOEING				OTHERS
A320	A330	A350	A380	B737	B747	B767	B777	(*)	
●	●	●	●	●	●	●	-	-	

(*) Indicated for other platforms, contact ATTAX for more information

COMPONENTS

	Material	Treatment
Body	Steel 4140 per AMS 6349	Zinc Nickel Type II Grade B per AMS 2417
Plunger	Steel 42CrMo4 per EN 10293	Zinc Nickel Type II Grade B per AMS 2417
Lever	--	--

DIMENSIONS

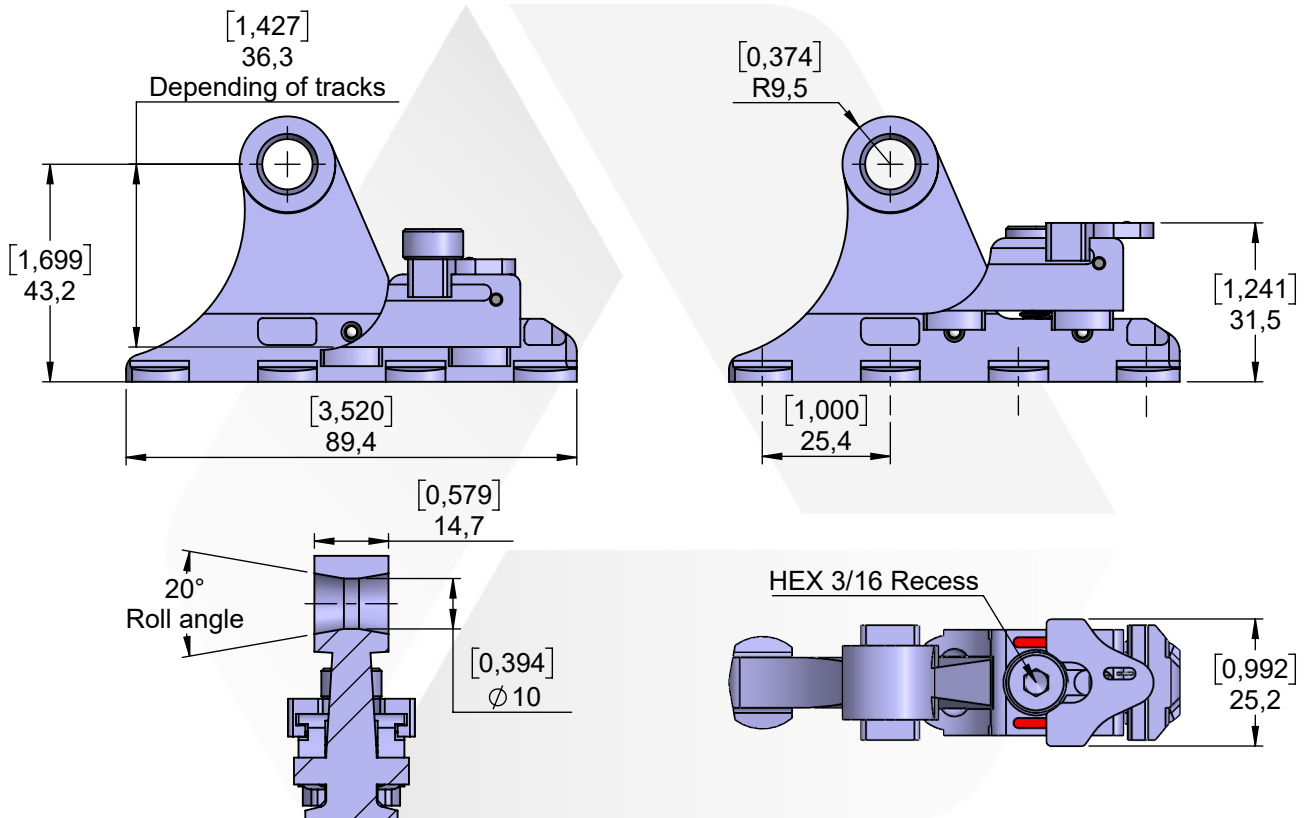

Technical data

Safety indicator: Yes	Tool-less	No	Secured locking	Yes
Red Yes	Quick release	No	Offset	No
Green No	Positive engagement	Yes	Captive screw	Yes