



## 50T3R1010-ZN

■ REAR TRIPLE STUD FITTING  
**Weight : 208 g**

### FEATURES

Characteristics	
Fitting class	Torque
Number of studs	3
Shear plunger	Yes
F <sub>xz</sub> (for rear) / F <sub>z</sub> (for front)	> 75 KN

Aircrafts									
AIRBUS				BOEING				OTHERS	
A320	A330	A350	A380	B737	B747	B767	B777	(*)	
●	●	●	-	●	●	●	-	-	

(\*) Indicated for other platforms, contact ATTAX for more information

### COMPONENTS

	Material	Treatment
<b>Body</b>	Steel 4140 per AMS 6349	Zinc Nickel Type II Grade B per AMS 2417
<b>Plunger</b>	Steel 42CrMo4 per AMS 6349	Zinc Nickel Type II Grade B per AMS 2417
<b>Lever</b>	Steel 42CrMo4 per AMS 6349	Zinc Nickel Type II Grade B per AMS 2417

### DIMENSIONS

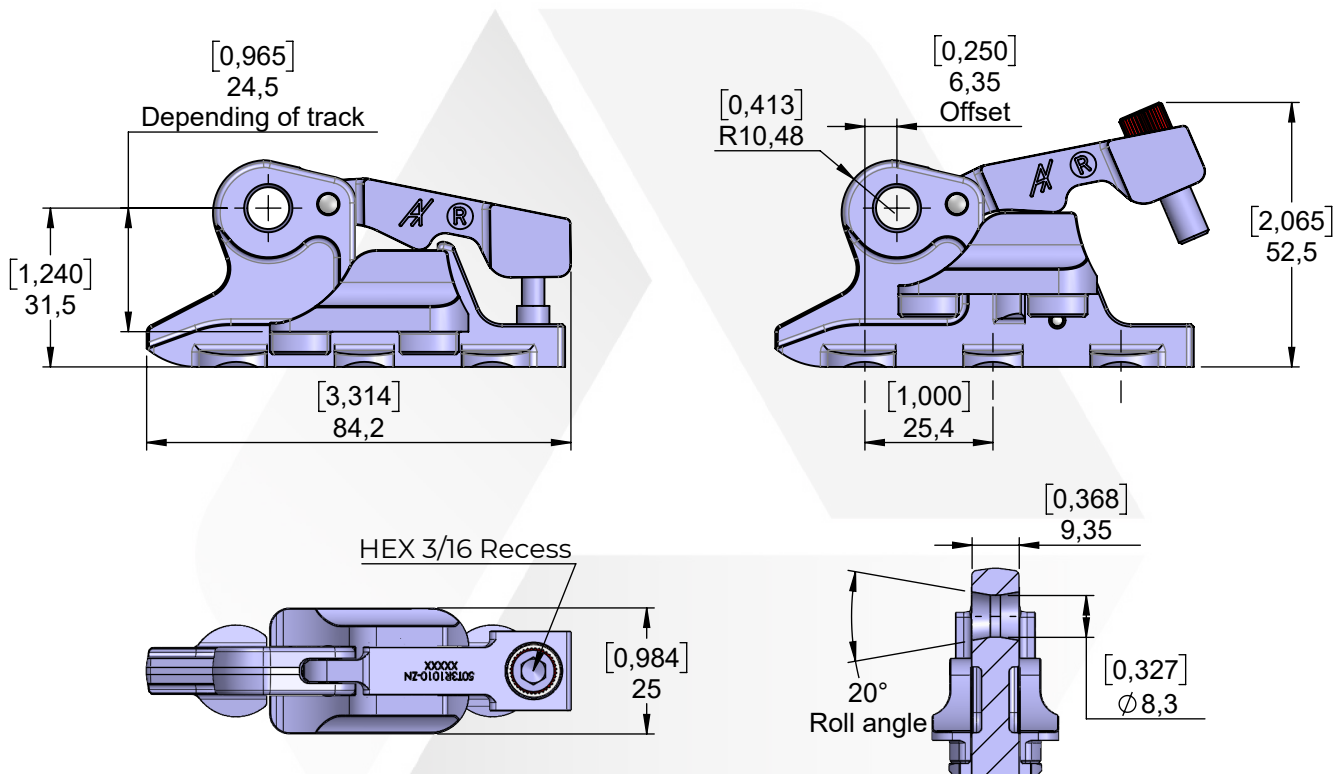

Technical data				
Safety indicator: Yes	Tool-less	No	Secured locking	Yes
Red Yes	Quick release	No	Offset	Yes
Green No	Positive engagement	Yes	Captive screw	Yes