

## 50T4R2003-ZN

■ REAR QUADRUPLE STUD FITTING  
**Weight : 191 g**



### FEATURES

Characteristics	
Fitting class	Torque
Number of studs	4
Shear plunger	Yes
F <sub>xz</sub> (for rear) / F <sub>z</sub> (for front)	> 75 KN

Aircrafts									
AIRBUS				BOEING				OTHERS	
A320	A330	A350	A380	B737	B747	B767	B777	(*)	
●	●	-	-	●	●	●	-	-	

(\*) Indicated for other platforms, contact ATTAX for more information

### COMPONENTS

	Material	Treatment
<b>Body</b>	Stainless steel 17-4 Ph per ASTM A693	Zinc Nickel Type II Grade B per AMS 2417
<b>Plunger</b>	Stainless steel 17-4 Ph per AMS 5355	Zinc Nickel Type II Grade B per AMS 2417
<b>Lever</b>	--	--

### DIMENSIONS

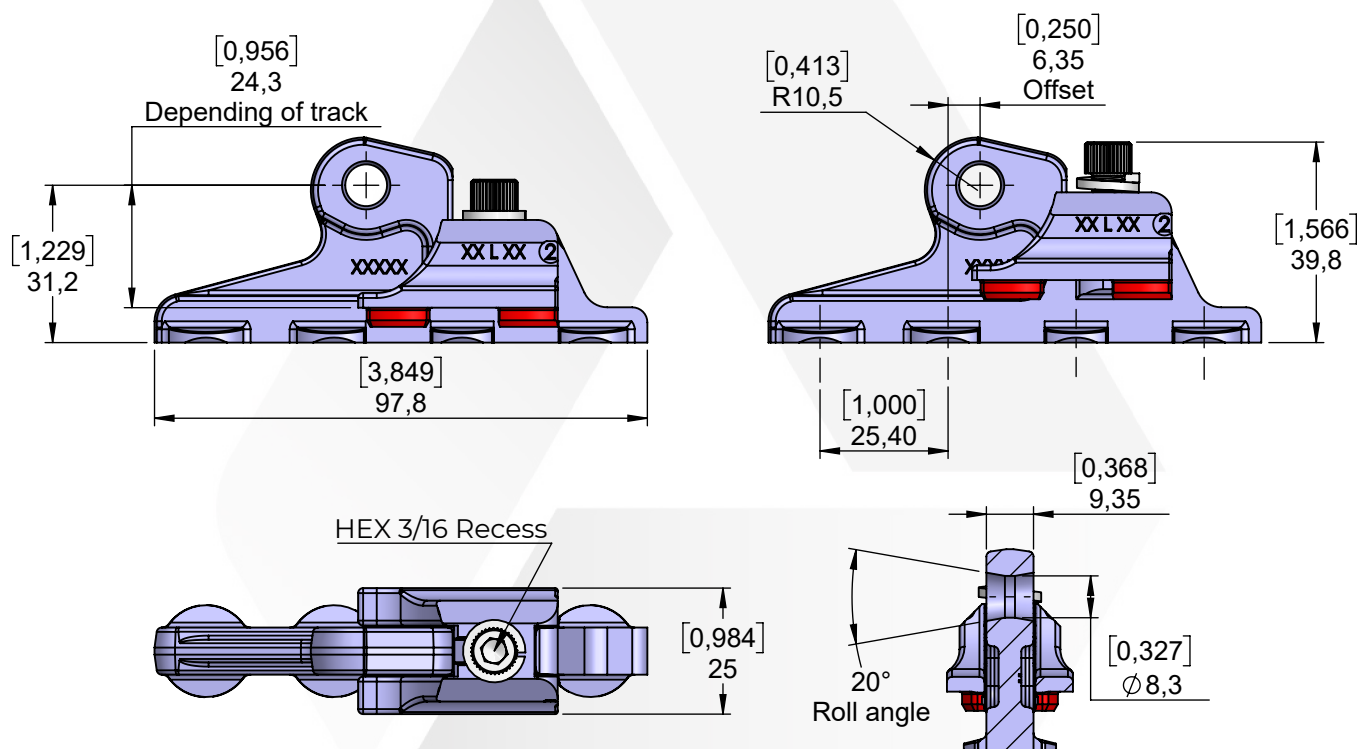

Technical data				
Safety indicator: Yes	Tool-less	No	Secured locking	No
Red Yes	Quick release	No	Offset	Yes
Green No	Positive engagement	No	Captive screw	No