



50T4R2005-ZN

■ REAR TRIPLE STUD FITTING
Weight : 228 g

FEATURES

Characteristics	
Fitting class	Torque
Number of studs	4
Shear plunger	Yes
F _{xz} (for rear) / F _z (for front)	TBD

Aircrafts									
AIRBUS				BOEING				OTHERS	
A320	A330	A350	A380	B737	B747	B767	B777	(*)	
-	-	-	-	●	●	●	-	-	

(*) Indicated for other platforms, contact ATTAX for more information

COMPONENTS

	Material	Treatment
Body	Stainless steel 17-4 Ph per ASTM A693	Zinc Nickel Type II Grade B per AMS 2417
Plunger	Steel 42CrMo4 per AMS 6349	Zinc Nickel Type II Grade B per AMS 2417
Lever	Steel 42CrMo4 per AMS 6349	Zinc Nickel Type II Grade B per AMS 2417

DIMENSIONS

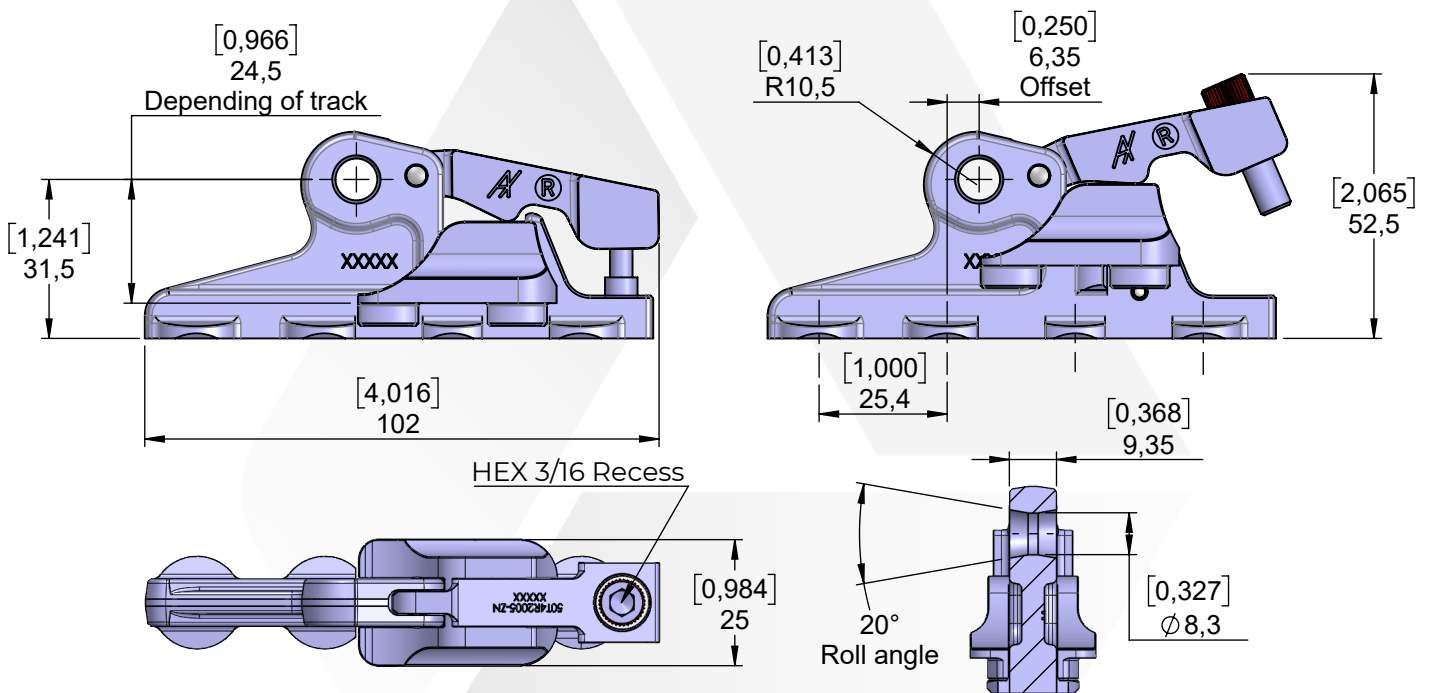

Technical data					
Safety indicator:	Yes	Tool-less	No	Secured locking	Yes
Red	Yes	Quick release	No	Offset	Yes
Green	No	Positive engagement	Yes	Captive screw	Yes